

WARING COMMERCIAL

Europe Medium Duty Bar Blender
with Electronic Keypad, 99 Sec. Countdown
Timer and Stainless Steel Container

BB340SE

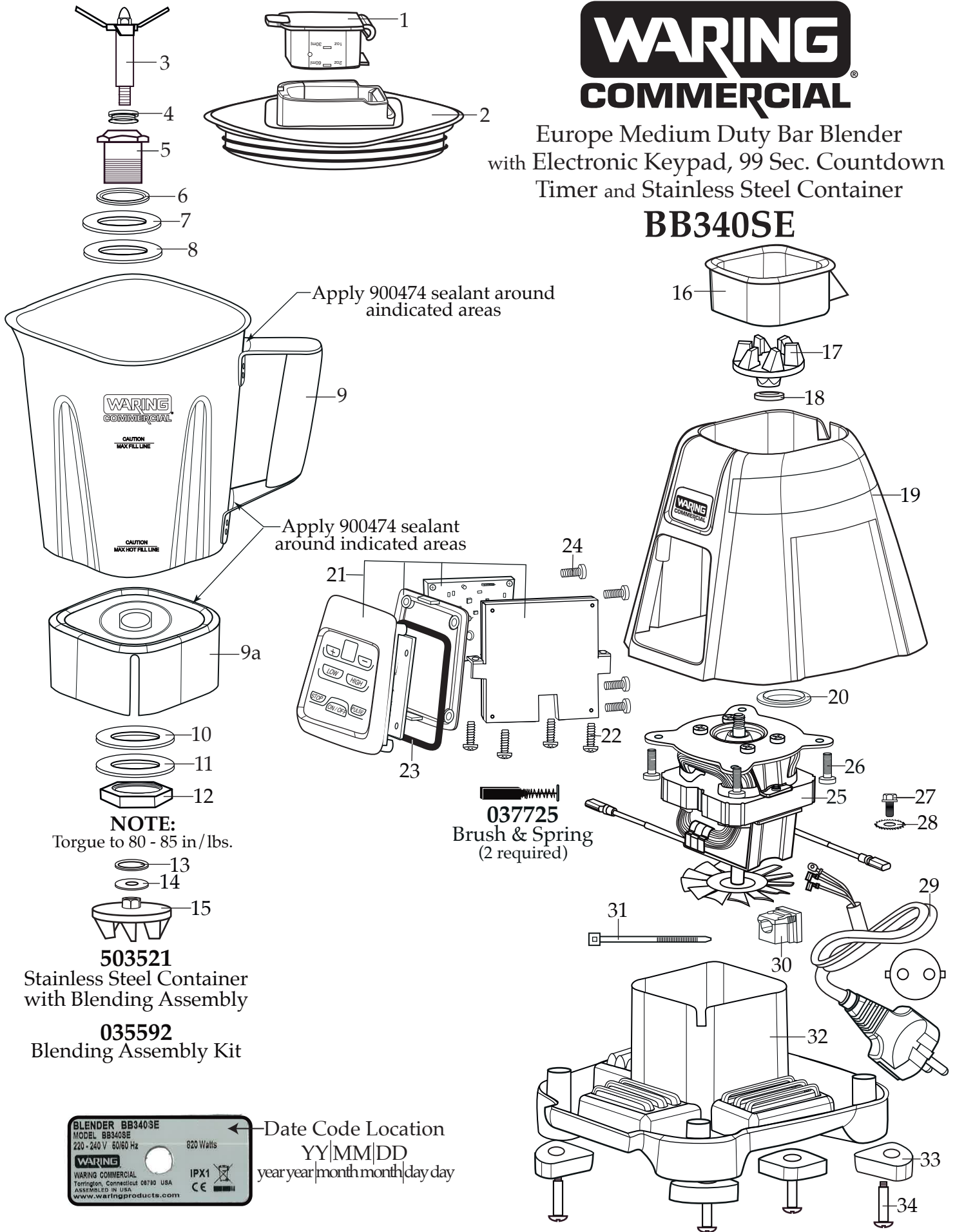

Illustration#	Part#	Description
1	035153	Jar Lid Cover
2	036319-P 033625-M	Jar Lid <i>(on units after 2/1/2020)</i> Monoprene Jar Cover
3	503444	Blade Assembly
4	027716	V Seal
5	503458	Bearing Holder / Seal Assembly
6	009724	Nylon Flat Washer
7	003537	Stainless Steel Washer
8	003509	Neoprene Washer (rubber)
9	034775	Stainless Steel Container
9a	034776	Jar Bottom
10	003509	Neoprene Washer (rubber)
11	003537	Stainless Steel Washer
12	034156	Bearing Holder Nut
13	003526	Phenolic Washer
14	035048	Flat Stainless Steel Washer
15	503520	Couping
16	033623	Jar Pad
17	503520	Couping
18	035756	Stainless Steel Cap Washer
19	033616	Top Housing
20	026269	Upper Motor Mount
21	035417	PCB Control Panel
22	033526	Screw (4 required)
23	033737	O Ring
24	026267	Screw (4 required)
25	035170	230 volt Chiaphua Motor
26	032611	Screw (4 required)
27	027278	Ground Screw (2 required)
28	002943	Washer (2 required)

Illustration#	Part#	Description
29	503490	Cordset Assembly
30	033619	Strain Relief
31	013731	Wire Tie (2 required)
32	035282	Bottom Housing
33	035287	Foot (4 required)
34	035260	Screw (4 required)

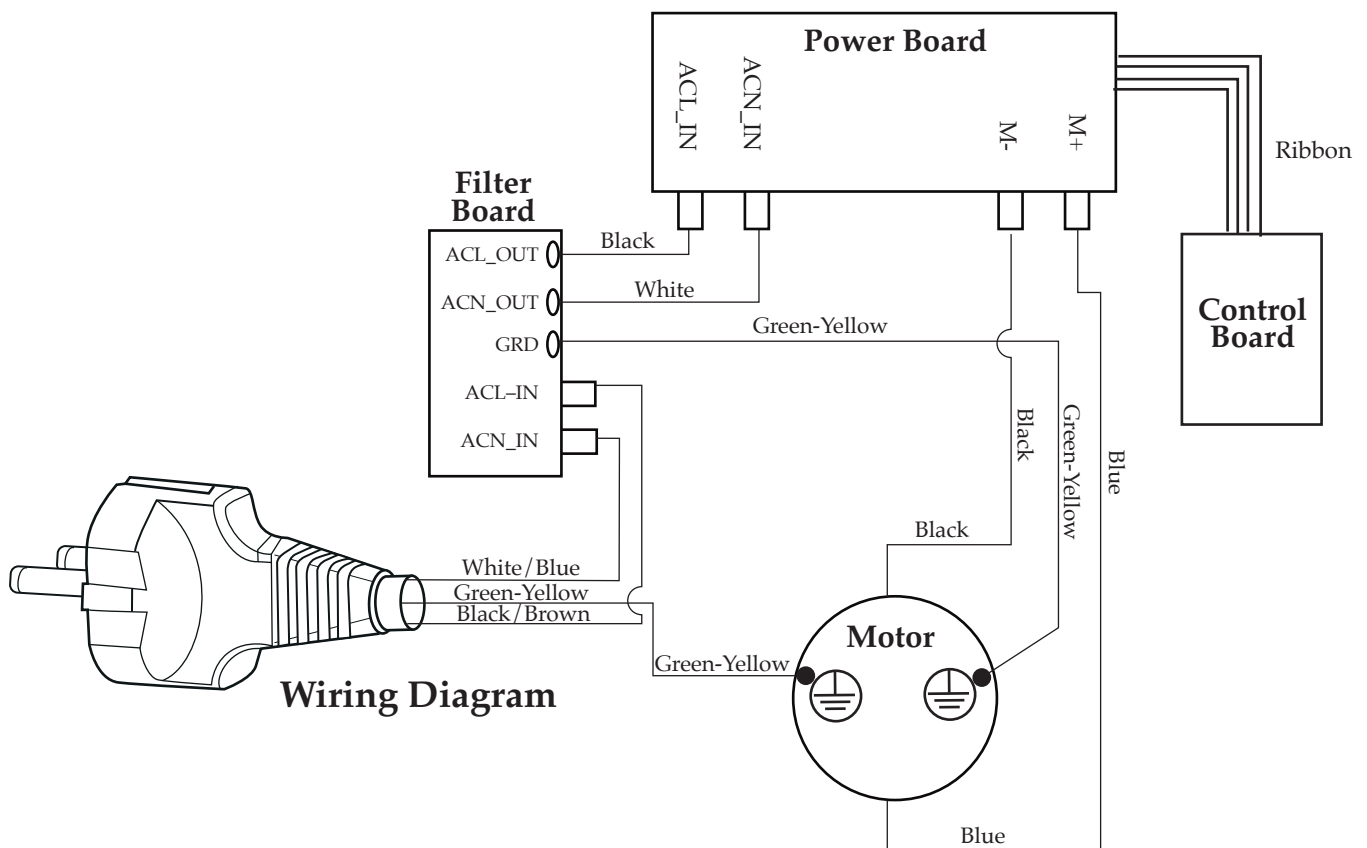

Wiring Diagram